

veritas[®]

**Low-Angle and
Standard Block Planes**



The Veritas® Block Planes measure 6½" long by 2" wide. The body is ductile cast iron, a material much more durable as well as more stable than gray iron, having been fully stress relieved. The body is accurately machined so that the sole is flat, the sides are square to the sole, and the bed is flat and square to the sides. The large side wings increase stability for shooting and the unique triple finger grip indentations provide comfort and control. The plane's adjustable mouth may be closed to a narrow slit for fine shavings with minimum tear-out or opened for heavier cuts. Adjustment is done quickly and easily with a brass locking knob. The 1⅝" blade, at ⅛" (0.125") thick, is 1½ times the thickness of standard (0.080") plane blades, and is available in either A2 tool steel hardened to Rc60-62 or O1 tool steel hardened to Rc58-60. The excellent damping qualities of the blade combined with the solid bed and clamping system virtually eliminate chatter under all conditions.

The low-angle block plane has a bed angle of 12° and the standard block plane has a bed angle of 20°. The blade has a finely ground bevel of 25°.

The lever cap is molded to comfortably fit the palm of the hand, as well as to securely hold the blade directly over the bed at the front and on a large clamping pad at the rear. The lever cap wheel (underneath at the rear of the lever cap) can be easily set from a full locking position to a controlled friction setting for blade adjustment. The combined feed and lateral adjustment mechanism makes blade setting accurate and easy.

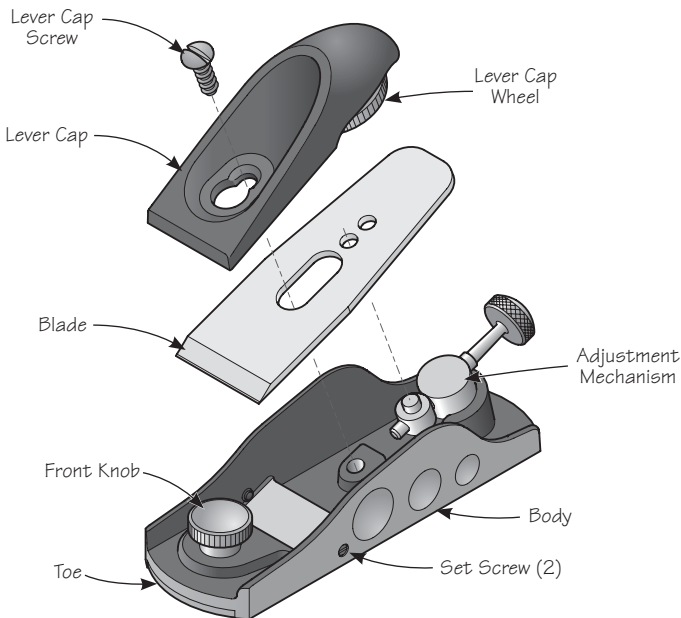

Figure 1: Plane components.

Instructions

The Veritas® Block Planes may be used with one or two hands. For a one-handed grip, put the tip of your index finger in the front knob depression, rest your palm on the lever cap and grip the plane sides with your second and third fingers in the middle and rear indentations on one side and your thumb in the forward indentations on the other side.

For additional force (or control) you can use a two-handed grip with the front of the plane held with one hand and the other hand using the side indentations, or you can augment the one-handed grip by pinching the leading corner of the body between the thumb and forefinger of the other hand.

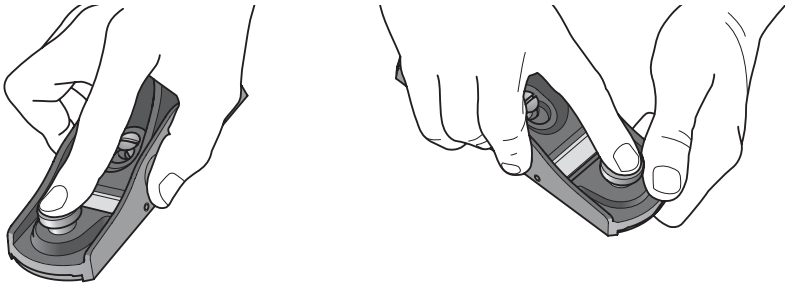



Figure 2: Holding the plane.

Blade Adjustment

 **Caution:** Be aware that the blade is sharp; careless handling can result in serious injury.

To initially set the blade, open the mouth fully, and place the plane on a flat wood surface (e.g., a scrap of stock). Lightly clamp the blade with the lever cap wheel and advance the blade until it just touches the wood.

Flip the plane to a sole-up position, then sight along the sole to ensure the blade edge is parallel to the sole and advance or retract it as required. Clamp fully (a quarter turn should be ample – **do not overclamp**) and take a test cut. If all is well, advance the set screws on either side of the body until they just touch the blade, not to clamp it but to create a guide so that you do not have to be concerned about the blade shifting sideways at the front. All lateral adjustment will now be governed solely by movement of the lateral adjust/feed lever. This is a substantial advance over all other designs, which either have a milled slot at the front and no lateral adjust, requiring you to sharpen your blade to exactly 90° to the blade side, or have room for the blade to shift sideways at the tip every time you want to change your depth of cut.

You will quickly get accustomed to setting blade depth only by sighting along the sole, but for setting very fine shavings, you will still need to take test cuts.

Two Cautionary Notes:

1. *The lever cap clamping wheel has tremendous mechanical advantage. For normal use, it needs to be tightened only a quarter turn after full engagement with the blade. **Never torque it down as hard as you can or you may damage the plane.***
2. *Before advancing the blade at any time, check the mouth opening to be sure you don't run the blade against the adjustable toe piece. It is a simple matter to close the mouth to the desired opening **after** you have reached the right blade projection. Better to dull the blade in use than when adjusting it.*

Backlash and How To Avoid It

To eliminate the possibility of the blade shifting backward unpredictably as the backlash is taken up, the final setting should always be made with the blade being advanced by the clockwise movement of the thumbscrew. If you need to retract the blade slightly, retract it more than required, and finish by **advancing** it to its desired position. This takes up all play in the forward direction, eliminating any shifting in use.

Mouth Adjustment

The movable toe piece enables you to quickly and accurately set the gap between the blade and the toe piece (this opening is called the mouth) to suit the task. Generally, you will want a mouth as small as will allow the shaving to escape. The reason for this is that a tight mouth supports the wood ahead of the blade, preventing break-out, a shaving propagating below the surface of the workpiece.

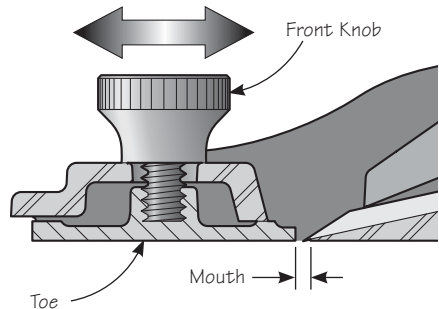

Figure 3: Mouth adjustment.

Loosen the front knob and adjust position of the toe by sliding the front knob forward or backward as required. Tighten the front knob firmly, but avoid overtightening.

The toe is designed so that it never extends beyond the front of the plane body, even when set to the largest mouth opening. This prevents the toe from being inadvertently shoved back into the blade and damaging it, should the front of the plane come up against an obstacle or the plane be dropped toe first on the bench or floor.

Applications

Both block planes can be used for general-purpose work, such as chamfers, trimming and fitting moldings, fitting drawers, and small smoothing operations. The low-angle block plane is also ideal for working end grain, such as squaring or trimming.

Cutting End Grain

Cutting end grain is very different from planing with the grain; it calls for a lot of pressure and control. In fact, cutting end grain requires nearly three times the force that it takes to cut parallel to the grain. You can do four things to make end-grain cutting easier. First, keep the edge of the blade as keen as possible. Second, take lighter cuts. Third, keep the bevel angle of the blade as low as possible and consistent with edge retention; however, this is a matter of trial and error. You start with a low bevel angle and increase it only if you get edge failure. The failure is quickly evident by scratches showing up on the end grain. Fourth, skew the plane. Instead of cutting directly across the grain, hold the plane askew to the path of travel. This has exactly the same effect as lowering the bevel angle, because it lowers the cutting angle. If you have a 37° cutting angle, by rotating the plane 45° and taking a skew cut, you will get the same cutting action that you would if you had lowered the bevel angle to 28° . If you skewed the plane even more, say to 60° , you would get a cutting angle of 21° . The edge does not fail because exactly the same amount of distortional force is being applied over greater blade width. This leads directly to one of the little-known facts about tool technique – a blade used at a skew can be sharpened at a lower angle than a blade used to cut squarely across the wood, and the skewed blade will still retain its edge.

Planing end grain involves a lot of force. It is therefore important to have the workpiece firmly clamped in position. If possible, clamp the workpiece upright in a vise, keeping it low so that it will be secure and comfortable to work. You can prevent the edge of the workpiece from splitting when planing end grain by clamping a small scrap block to the edge.

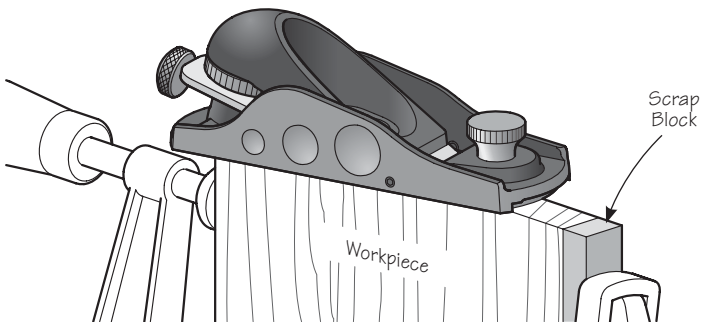

Figure 4: Preventing splitting.

Another way to plane end grain is to make use of a shooting board. It guides the plane to cut a perfectly square edge (or a bevelled edge if you want), and holds the workpiece in such a way as to prevent splintering of the end-grain fibers. Shooting boards can be as simple as illustrated or arranged in such a way as to shoot miters or configured with a molded stop to fit a matching molded profile.

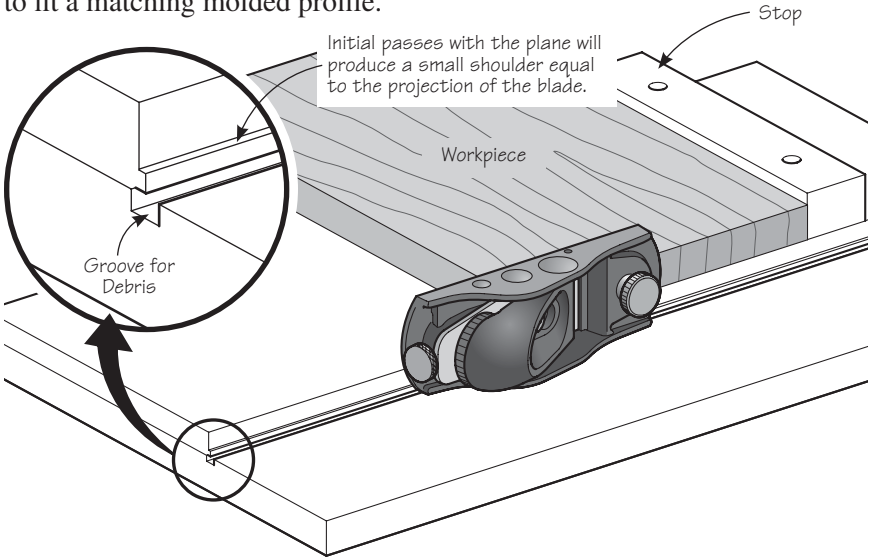

Figure 5: Planing end grain with the low-angle block plane.

Blade Sharpening

Low-Angle Block Plane

The low-angle block plane has a bed angle of 12° and the blade comes honed at an angle of 25° . Since the blade is used bevel up, the effective cutting angle will be 37° .

The 25° blade bevel is ideal for fine trimming work on end-grain softwood and some hardwoods. Ring-porous hardwoods such as oak may require a 30° bevel to prevent blade edge failure. Simply hone the micro-bevel to the required angle.

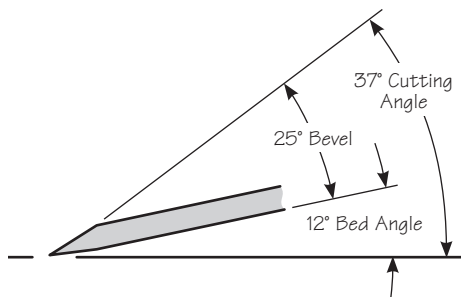

Figure 6: Blade geometry of the low-angle block plane, as supplied.

It is difficult to be definitive about many of these bevel angles. Some people never skew a block plane in use; other people always skew it. If you normally use a block plane in a skewed position, you can get away with lower bevel angles. If you are always working clear pine, you can get away with very low

bevel angles. Only you know which wood you will be working and how you will be working it. Experience will tell you what you can and cannot do.

With your bevel and cutting angles set for the demands of end-grain work, you will easily deal with parallel grain cutting.

Standard Block Plane

The blade on the standard block plane comes with a 23° primary bevel and a finely ground 25° micro-bevel. This configuration provides a strong, long-wearing edge that can be quickly honed many times before the primary bevel needs to be reground.

The standard block plane has a bed angle of 20°, which together with the blade micro-bevel angle of 25°, results in an effective cutting angle of 45°.

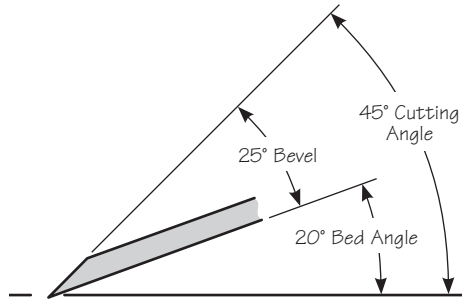

Figure 7: Blade geometry of the standard block plane, as supplied.

Some of this material is extracted from *The Complete Guide to Sharpening* by Leonard Lee, reprinted here with permission of the publisher, Taunton Press of Newton, CT.

Care and Maintenance

The body of the block plane is ductile cast iron and comes treated with rust preventative. Remove this using a rag dampened with mineral spirits. Clean all machined surfaces.

We recommend that you initially, then periodically, apply a light coat of paste wax to seal out moisture and prevent rusting; this also has the added bonus of acting as a lubricant for smoother planing. Wipe off any wood dust from the surfaces that you will be waxing, apply a light wax coating, let dry, then buff with a clean soft cloth. At the same time, the solvents in the wax will remove any harmful oils left from your fingers that can lead to corrosion.

Keep in mind that paste wax contains silicone that, if transferred to your workpiece, could cause finishing problems such as "fish eyes". To avoid this problem, use silicone-free products, such as Waxilit® sliding agent and glue release, or a tool surface sealant. Either is an excellent alternative to regular paste wax. However, before treating a plane with a sealant, wipe off any fingerprints with a cloth dampened with a small amount of light machine oil. Remove any residual oil; then apply the sealant to the plane's sole and cheeks.

If storage conditions are damp or humid, the plane should, in addition to the treatment outlined above, be wrapped in a cloth or stored in a plane sack. This precaution will also guard against dings and scratches.

Every so often, take the plane apart to clean and lubricate it where necessary. Remove the lever cap, blade and adjustment mechanism. Clean all parts with a cloth dampened with a dab of light machine oil. The blade bed, as well as the adjustment components (pivot, threaded shaft and traveller), will benefit from a light coat of oil to keep them working freely. For corroded plane bodies, we recommend you first remove the rust with a fine rust eraser, then treat as described above.

The bright finish on the brass components can be maintained as above. If a patina finish is preferred, simply leave the brass components unprotected until the desired level of oxidation has occurred, then apply a sealant. If you want to make them bright and shiny again, you can revitalize the surface with a brass polish.

Accessories

- 05P22.02** 25° A2 Blade, 0.125" × 1⁵/₈"
- 05P22.07** 38° A2 Blade, 0.125" × 1⁵/₈"
- 05P22.08** 50° A2 Blade, 0.125" × 1⁵/₈"
- 05P22.03** Ball Tail
(for Low-Angle Block Plane ONLY)
- 05P22.04** Tall Front Knob
- 05P22.05** Ball Tail and Tall Knob Set
(for Low-Angle Block Plane ONLY)
- 05P22.06** 38° Toothed Blade, 0.125" × 1⁵/₈"
- 05P22.10** Chamfer Guide
- 05P22.15** Handle, Large
- 05P22.17** Handle, Small
- 05P22.52** 25° O1 Blade, 0.125" × 1⁵/₈"
- 05P22.57** 38° O1 Blade, 0.125" × 1⁵/₈"
- 05P22.58** 50° O1 Blade, 0.125" × 1⁵/₈"



05P22.05



05P22.10

veritas® Tools Inc.

814 Proctor Avenue 1090 Morrison Drive
Ogdensburg, New York Ottawa, Ontario
13669-2205 USA K2H 1C2 Canada

customerservice@veritastools.com
www.veritastools.com